

# 2112 Multiplex Analyser

**The Rapidox 2112 Multiplex is housed in a 19" rack mount unit and allows a programmed sequence of gas samples to be fed to a single gas analyser, thus saving money and space requirements.**

Designed to work seamlessly in conjunction with any Cambridge Sensotec Rapidox gas analyser (R1100, R2100, R3100 & R7100 ranges), the unit can also be used with other manufacturers analyser equipment if required.

Available with 5, 10 or 15 independent gas inlet ports that are fed to a single gas outlet using a system of electronically controlled solenoid valves, the Multiplex comes in two designs: a more basic flow through design or a more complex bypass design (see schematics on page 2). The bypass design is more suitable for long distance tubing lengths as the sample ports are all sampled continuously via a secondary pump. This dramatically reduces the delay before a stable reading is obtained, when changing from one channel to the next.

Using the bespoke Rapidox software supplied with the 2112, the Multiplex is intended for fully automatic stand-alone operation. However, there is also a manual override dial on the unit allowing the user to select an individual channel of interest.

The Multiplex software allows the user to program how long each sample line is sampled for before moving to the next. If a channel is not required then it can be de-selected in the software and it will be skipped during the measurement cycle. The software also synchronises with the Rapidox analyser so that the user can easily tell which channel is being sampled at any time. The channels can be re-named for ease of identification and during data-logging they are identified by unique colour coding on the live time graph.

Due to the manual facility the Multiplex can be used with any other gas sampling systems or gas process applications requiring multiple sample points.

For customers requiring seamless integration of their multiplex unit with their Rapidox gas analyser, each unit is provided with software to connect both instruments together allowing synchronised data logging and channel identification.

- Specifically designed for use with a Rapidox gas analyser
- Flexible choice of channels used
- Flow through version for pressurised gas
- Bypass version for long sample tube lengths

- Manual or Automatic operation
- Software for programming a sample sequence
- Can be used with other manufacturers Gas Analysers



## Flow Through Version

This more basic and cost effective version uses a sequence of open and closed solenoid valves to allow gas to flow through the selected channel, but not through any of the others. This version is recommended if the gas is pressurised or flowing under its own means. It is also the preferred option should the gas be toxic (e.g. measuring carbon monoxide) as no unsampled gas can escape anywhere. If sample tube lengths are relatively short meaning that the time delay when switching from one channel to the next is not of much concern, then this unit is the recommended choice to buy.

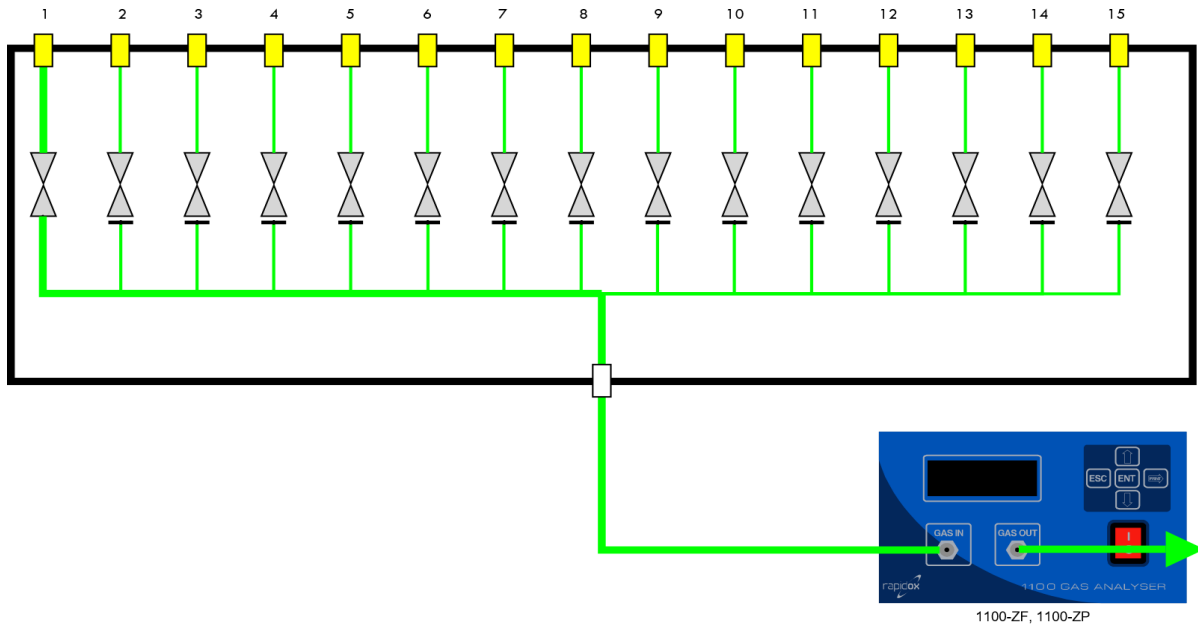

## Bypass Version

This more sophisticated version uses three-way solenoid valves so when a sample channel is closed the gas is bypassed and sent to an outlet port on the rear panel. The bypass tubes are connected together via non-return valves to prevent any bleed through of gases. In this configuration an optional sample pump or ejector can be attached to the outlet to allow all unused channels to be drawn continuously. Only the live channel is fed to the gas analyser. This is particularly suitable where the sample tubes are of considerable length, as it minimises the delay in measurement time when moving from one channel to the next. It is not suitable for pressurised gas applications or where the sampled gas is in limited supply. If using toxic gas great care must be taken to ensure the bypass port is vented safely via the pump.

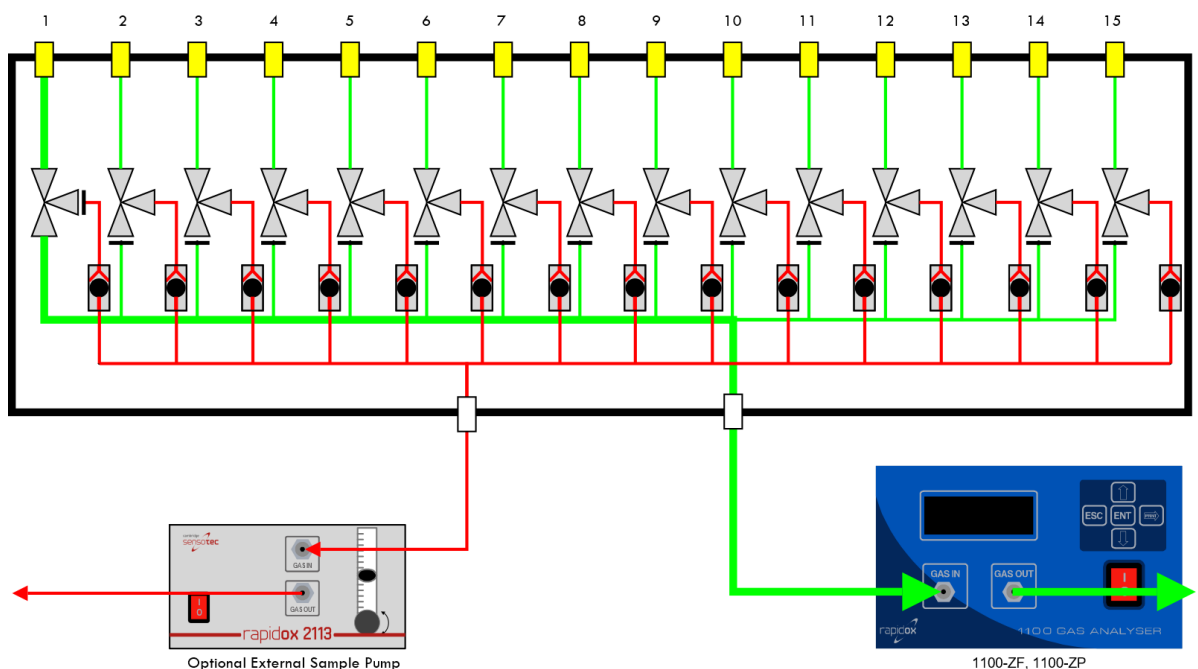



Multiplex running indicating channel 2 is currently being sampled.

Variations		
Feature	Bypass Version	Flow Through Version
5 - 15 channels available	Yes	Yes
Pressurised Gas Samples	No	Yes
Long Distance Sampling	Yes	No
Gas Consumption	More	Less
Cost	More	Less

Analyser Specification	
Supply Voltage	90–260VAC, 50/60Hz
Power Consumption	30W (max)
Analyser Dimensions	370mm (W) X 440mm (D) X 130mm (H)
Weight	7.5kg
Warm-up Time	60 seconds at 20°C
Normal Operating Temperature	5–35°C
Normal Operating Pressure	900–1100 mbar absolute
Operating Humidity	10 – 90% RH
Sampling	Manual or Automatic modes via 5, 10 or 15 independent gas inlet ports
Automatic Control	Via RS232 communications port using bespoke multiplex software provided
Connections	Nipple fittings for 6mm OD / 4mm ID sample tubing (FEP recommended)
Fuse	T2A H250V 5 x 20mm glass